



FEATURES

- Hermetically sealed
- Calibrated at real max. capacity

SPECIFICATIONS

Max. capacity	tf	20, 30, 50, 100, 200
Rated output	mV/V	2.0 ± 0.002
Zero balance	mV/V	0 ± 0.02
Combined error	%	0.15
Repeatability	%	0.1
Creep for 30 min.	%	0.03
Temperature effect on		
Zero Value	%/10°C	0.03
Output value	%/10°C	0.03
Excitation		
Recommended	V	10
Maximum	V	15
Resistance		
Input	Ω	350 ± 3.5
Output	Ω	350 ± 3.5
Insulation	M Ω	> 2,000
Compensated temperature range	°C	-10 to +70
Operating temperature range	°C	-20 to +80

DIMENSIONS

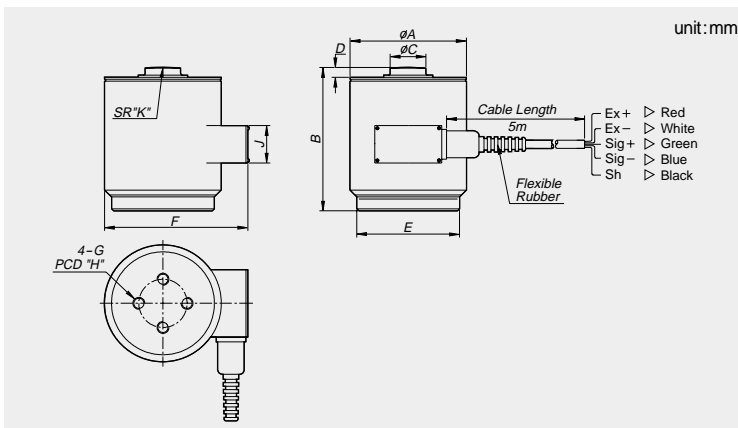

Material

Paint finished steel

Cable

Braided shield 4-wire round cable with P.V.C-jacket

Model	Capacity	øA	B	øC	D	E	F	G	H	J	K
HC-20	20tf	118	145	36	10	104	150	M12×1.75	80	38	150
HC-30	30tf	118	145	36	10	104	150	M12×1.75	80	38	150
HC-50	50tf	138	160	50	20	124	170	M12×1.75	80	38	200
HC-100	100tf	158	190	70	20	144	190	M16×2.0	100	38	200
HC-200	200tf	214	230	95	30	188	249	M16×2.0	130	38	300